

# **ANDRITZ reactor internals**

Engineered for reliability



# Contents

Welcome to ANDRITZ .....	05
<b>Axial flow reactor .....</b>	<b>07</b>
Feed diffuser .....	08
Liquid distributor tray .....	10
Support grid .....	12
Quench pipe and mixing tray .....	16
Outlet collector and support grid .....	18
Header and hub lateral systems .....	20
<b>Radial flow reactor .....</b>	<b>25</b>
Center pipe .....	26
Scallops .....	28
Outer basket .....	30
SSR-Flow .....	32
<b>Your partners for high-quality reactor internals .....</b>	<b>35</b>

# Welcome to ANDRITZ

## Globally operating service and supply of reactor internals

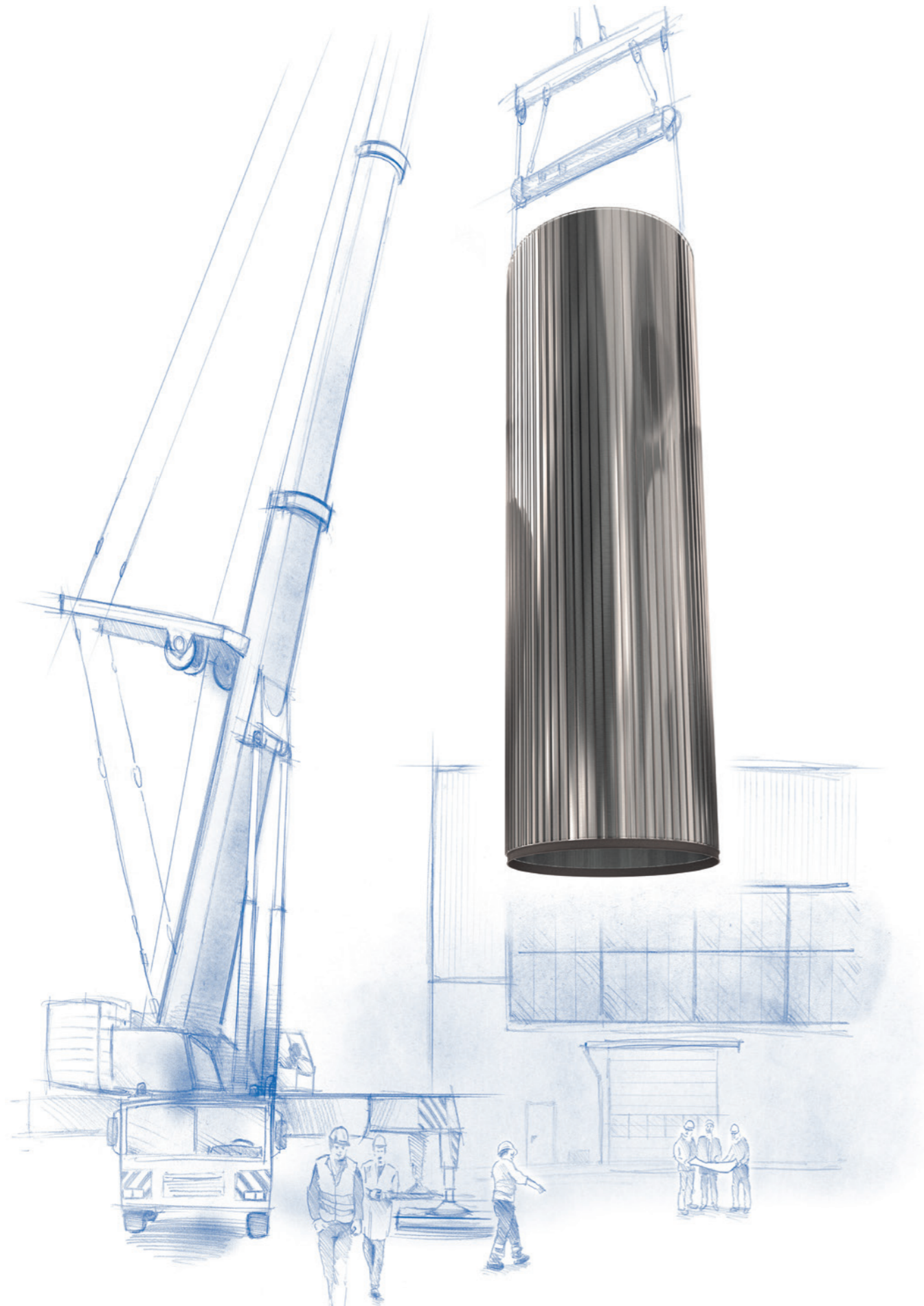

Thanks to decades of international experience, ANDRITZ has the skills and know-how to provide just the right products and services exactly when and where you need them. No matter what make or model, what time frame or what location, we provide you with a full range of services from a single source. Whether you need repairs, maintenance, reprocessing, planning of new installations, or optimization of your existing components – you can count on the expertise of ANDRITZ.

### Comprehensive on-site service

No matter where in the world you are based, our expert service teams can be on site within 48 hours. In case of unexpected damage, we'll provide valuable support to ensure a feasible and fast way of procuring new parts and carrying out repairs. For scheduled shutdowns, we'll ensure precisely executed operations with qualified personnel from Safety Certificate Contractors (SCC) in accordance with the plans as agreed. From risk assessment and detailed planning to rapid implementation and successful completion – we've got the

right people and the right equipment to get the job done.

### Installation

The installation of plants and equipment in the petrochemical and refining industries can be time-critical. That is why our specialist supervisors are able to fit quickly and effortlessly into any team, adding real value with their depth of experience to ensure trouble-free installation. Thanks to our flexibility and "thinking out of the box" attitude, we are also able to take on new projects and ideas, where more traditional companies might be hampered by rigid procedures.

### Maintenance, shutdown, or revamp

ANDRITZ's planned maintenance services give you access to highly skilled engineers and technicians who work closely with you on all elements of a shutdown in order to complete the work safely and efficiently. Our on-site experts provide and share expertise in order to help you plan and monitor the maintenance, and you are always kept up to date on the latest preventive

maintenance techniques to minimize unplanned downtime. Our teams will strip down, diagnose, re-engineer and replace defective components fast – often improving the design in the process.

### Ready to manufacture

ANDRITZ has manufacturing drawings for all required spare and wear parts, whether OEM or non-OEM. As we have all materials in stock, we do not have to start a time-consuming re-engineering process and can begin producing your reactor internals right after order placement. We are your one-stop-shop for all reactor internals.

### Comprehensive consulting

ANDRITZ has all production facilities under one roof. That is why, unlike other producers of reactor internals, we are able to provide the best possible independent and neutral advice as to which products fit your application. Whether drilled, punched or wedge wire technology – our service team is at your side to help you find the perfect solution.

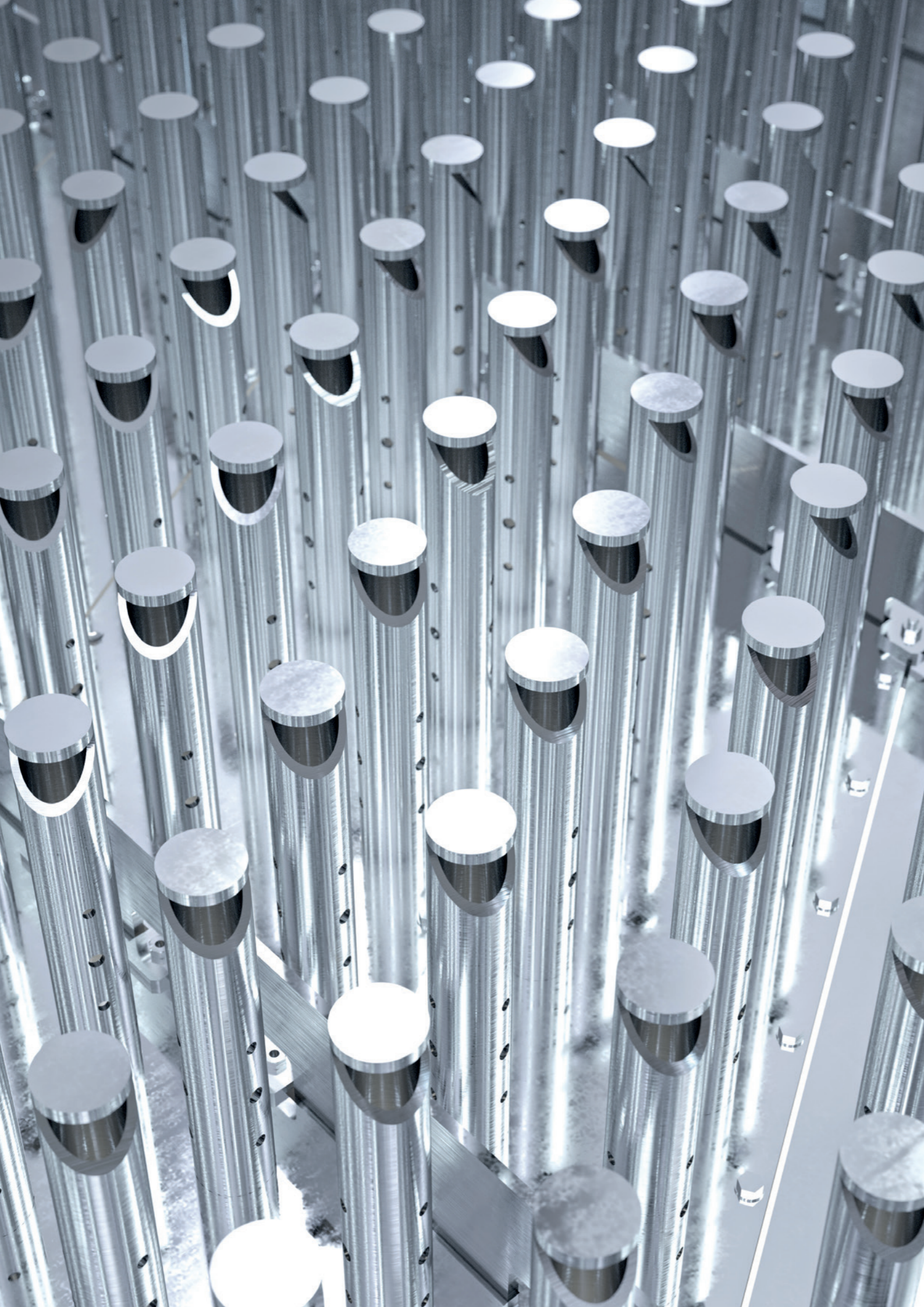

# Axial flow reactor

## Internals and solutions

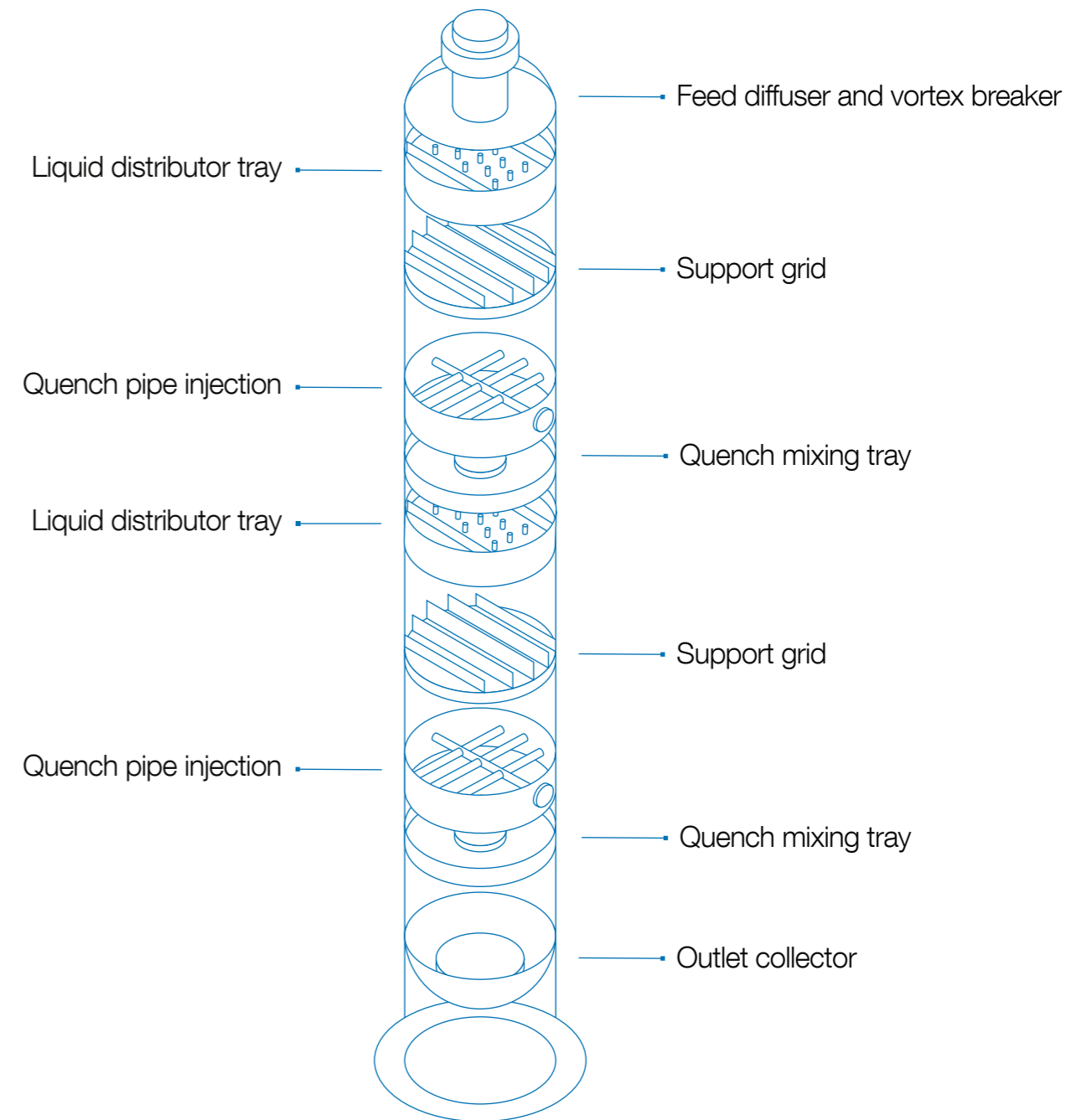

# Feed diffuser and vortex breaker

## Initial distribution

# Design according to your application

## Meeting specific process requirements

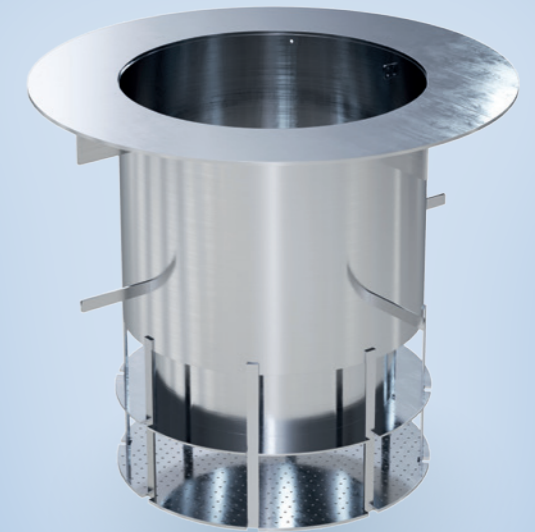
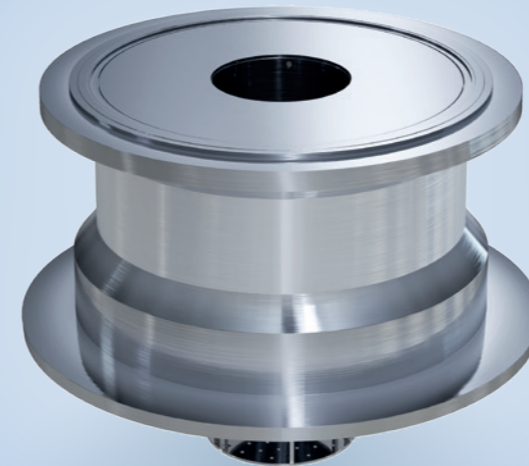
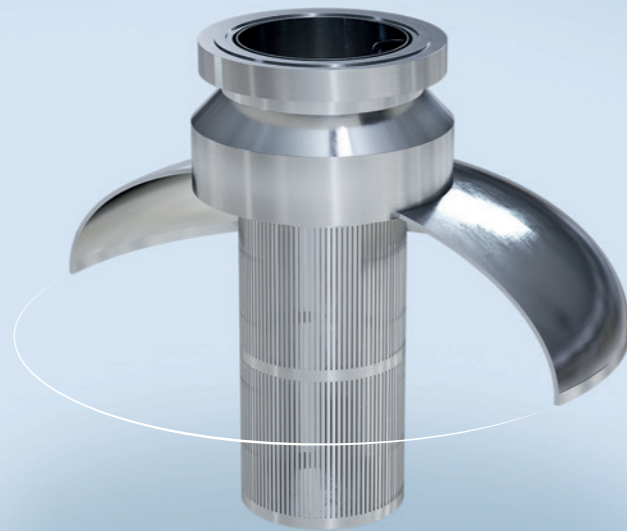
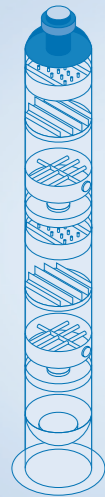

▲ Feed diffuser

▲ Feed diffuser

▲ Feed diffuser

### Operating principle

The feed diffuser guides the incoming flow from the inlet nozzle towards the reactor.

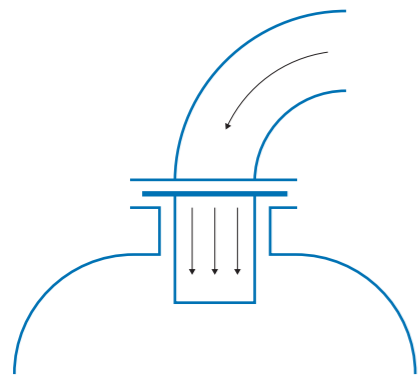

▲ Assembly between flanges

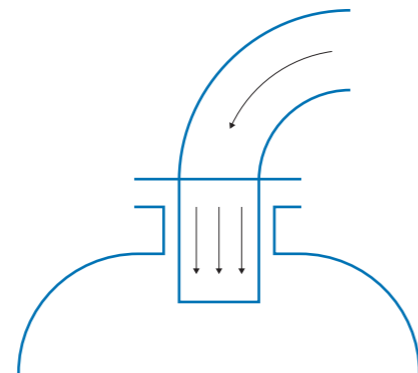

▲ Assembly by welding

### Process and features

In a downflow reactor, the inlet nozzle is often used as a manhole for installation of internals and catalyst loading. The feed diffuser can either be attached to this flange or positioned in a groove between the flanges. Depending on the flow dynamics

of the top reactor head and process operation, the feed diffuser or vortex breaker is made out of a mix of plate, screen, and perforated plate. An impingement plate normally faces the incoming flow, which may be diverted through several channels.

Its size depends on the incoming pipe diameter and the nozzle height. In upflow patterns, the feed diffuser is positioned above the inlet nozzle. Removable equipment that enables easy cleaning of the parts may be required.

# Liquid distributor tray

Collection and uniform distribution

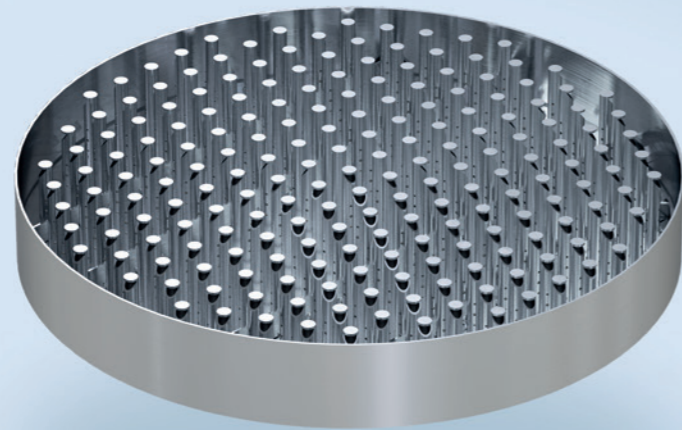
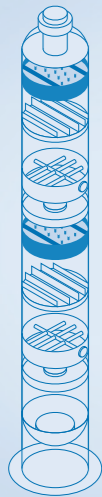

▲ Liquid distributor tray, design variant

# Design according to your application

Meeting specific process requirements

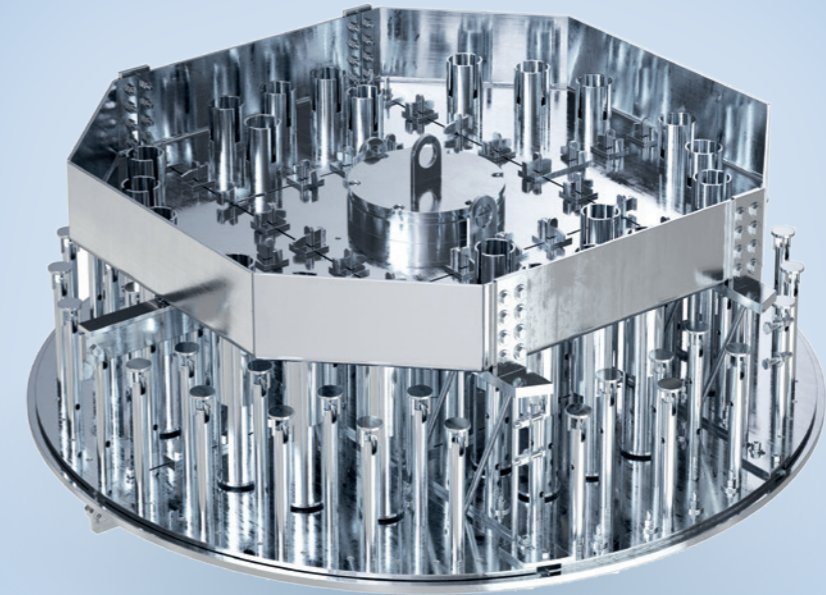

▲ Liquid distributor tray, design variant

## Operating principle

The liquid distributor tray distributes the incoming flow over the entire vessel cross section.

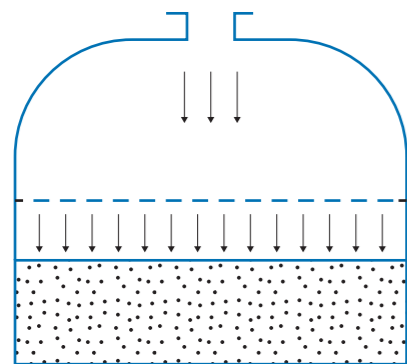

▲ Flow distribution over the bed

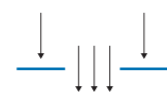

▲ Sieve tray

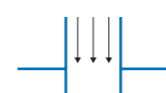

▲ Simple chimney

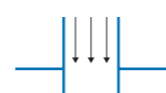

▲ Chimney with crushing plate

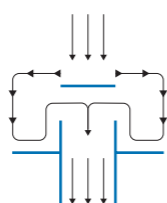

▲ Chimney with top cap

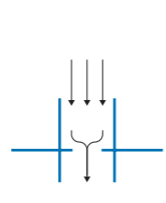

▲ Chimney with calibrated hole

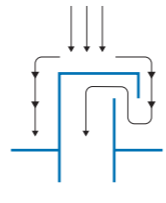

▲ Chimney with mitred end cap

## Process and features

Performance of the catalyst in an axial flow reactor very much depends on the hydraulics of the flow distribution system. Whether in upflow or in downflow operation, uniformity of the flow distribution is key for an even transit time, catalyst use, and catalyst deactivation. In ideal conditions, the plug flow is controlled in order to obtain high-purity products. Distribution is critical in a two-phase flow: when

liquid and gas are mixed, the pattern of liquid spreading in the gas or gas diffusion into the liquid is essential for the process chemistry. The liquid distributor system has to compensate the inconsistency of the incoming flow. The pressure drop must be controlled as it is a flow-reducing factor. Distribution is more critical for high-pressure reactors, where height saving significantly reduces the equipment costs,

or for revamp, where increased capacity is required for increased throughput. The flow is distributed via several distribution nozzles attached to the distributor tray. Each distributor nozzle constitutes a flow restriction using the Venturi effect. Nozzle spacing, pattern, and type depend on the respective application.

# Support grid

Effective retention for the catalyst

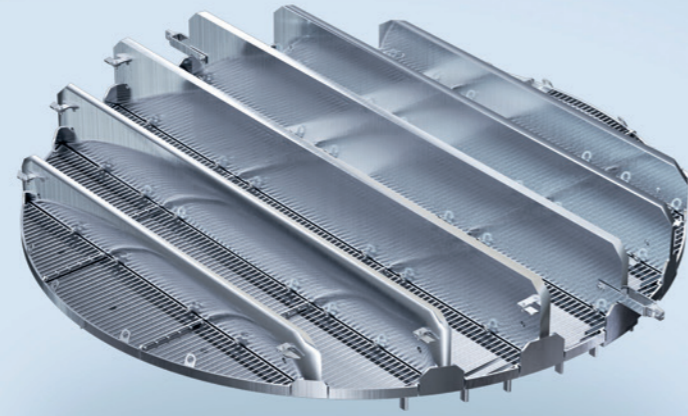

▲ Support grid

# Design according to your application

Meeting specific process requirements

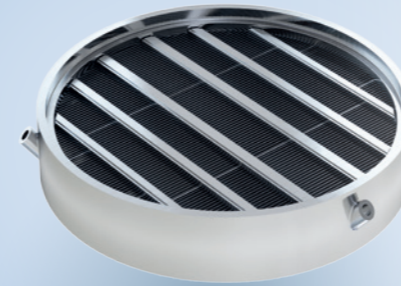

▲ Catalyst support grid

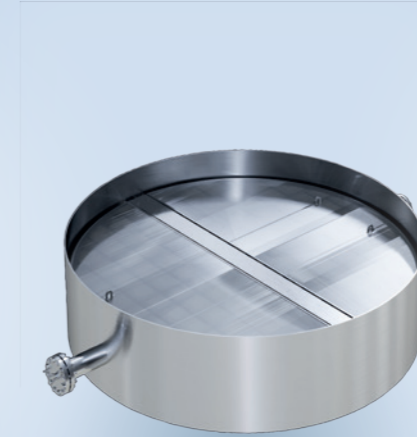

▲ Hinged support grid



▲ Support grid

## Operating principle

The support grid is a retention device for the catalyst and extends over the entire cross section of the vessel.

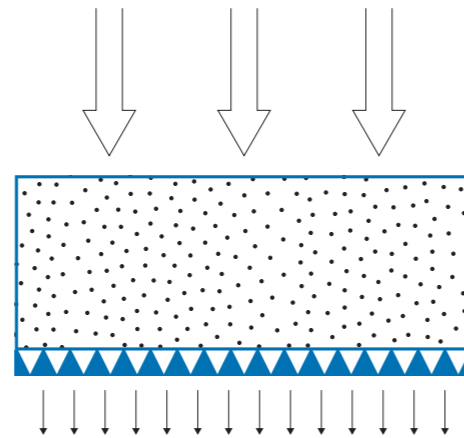

▲ Process fluid passing through the support grid surface

## Process and features

The catalyst is chosen for its efficiency, its stability, and selectivity. The required volume of catalyst is referred to the bed and extends over a fixed height for a given

reactor diameter. The catalyst can consist of different types of material with varying size and bulk density. The catalyst layers may extend into one bed or several beds

in a multi-bed reactor in such a way that several support grids have to be installed in the same reactor.

# Installation solutions for support grids

Variants for any system

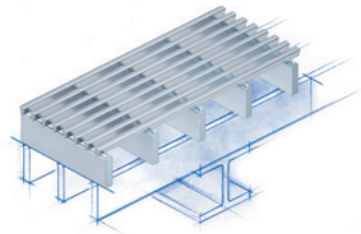

▲ Perpendicular reinforcement

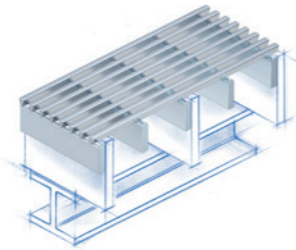

▲ SBS reinforcements

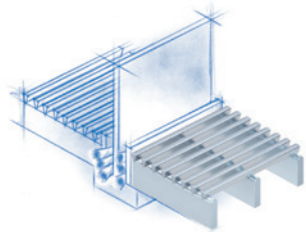

▲ T-beam

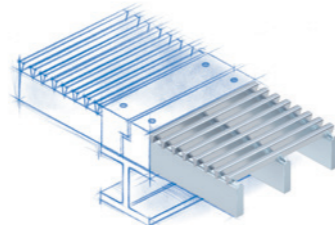

▲ I-beam

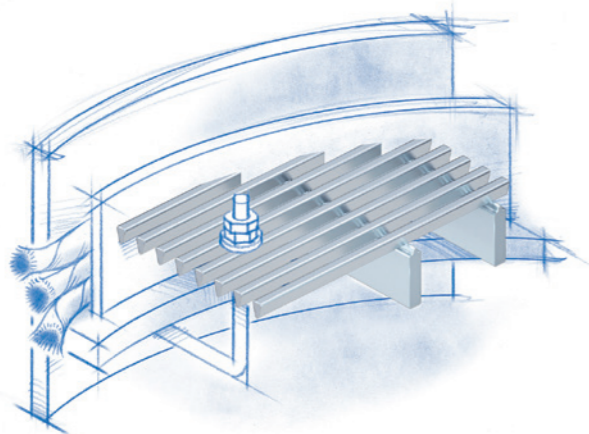

▲ J-bolts locking system

In axial flow operations, the support grid assembly has to withstand vertical process loads. The grids must be reinforced or supported by extra beams, adding extra strength to the assembly. Several schemes are shown here.

The perpendicular reinforcement system is reinforced by support rods, which are aligned at a 90° angle to the support grid. SBS or side-by-side reinforcement is welded to the support rod to gain additional support here. T-beams are generally used for high design pressure allowing the filter elements to be submerged in the catalyst bed at the height of the grid. I-beams, on the other hand, are more commonly used for lighter design pressure, enabling beams to be positioned below the grid.

The support grid is installed on a ring integral to the pressure shell. The grid must be built in sectors so that it can be installed through the vessel manhole. Some processes require a locking system to secure the panels, for example our reliable J-bolts locking system.

A small gap is left on the inside of the vessel wall in order to allow for differential thermal expansion and installation clearance and to handle manufacturing tolerances, or due to the round shape of the reactor itself.

# Trial assembly

Conducted manually for highest precision

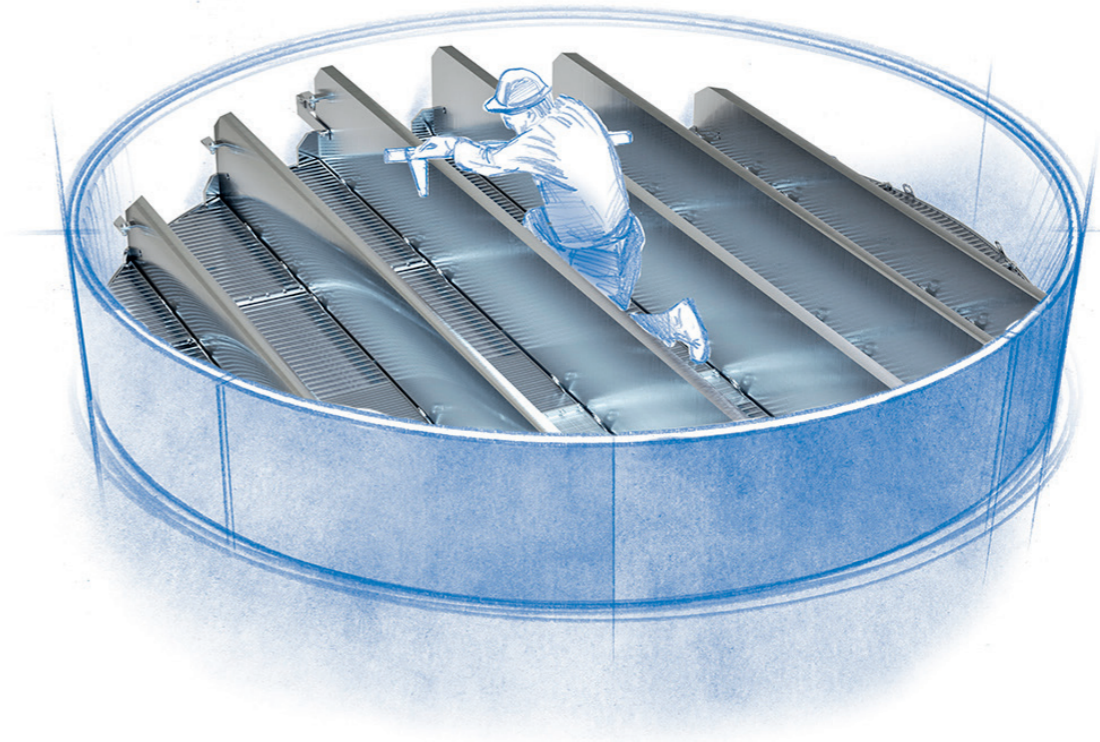

▲ Trial assembly in dummy shell

## We check before delivery

Grids can be arranged in parallel or like a pie chart. The overall assembly of the grids and beams requires particular attention because some parts are hyperstatic. Special care has to be taken to make sure that the overall assembly is truly horizontal

and that all gaps are closed. To prevent the possibility of fluidization of the catalyst during upsets in upflow reactors, hold-down grids can be placed above the catalyst bed.



# Quench pipe and mixing tray

## Elaborate flow management

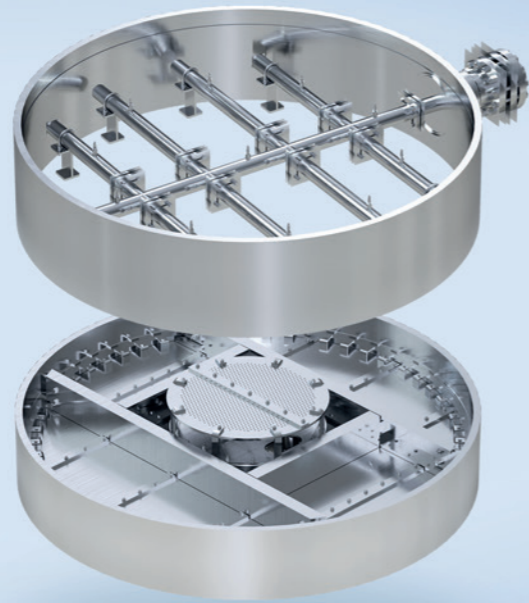
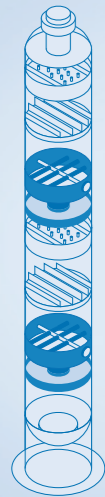

▲ Quench pipe and mixing tray

### Operating principle

The mixing system comprises a horizontal collection tray, a mixing chamber positioned below the collection tray, and at least one passageway extending through the collection tray into the mixing chamber. This mixing chamber and the col-

lection tray define a two-phase mixing volume. The passageway conducts fluid from above the collection tray into the mixing chamber, which preferably includes at least one outlet opening for the downward passage of fluid.

In particular, mixing of quench fluid is significantly improved when quench is introduced into a region above the collection tray and where a preferred direction of quench injection is selected to cause a rotational flow on the collection tray.

# Operating principle

## Injecting fluids for cooling

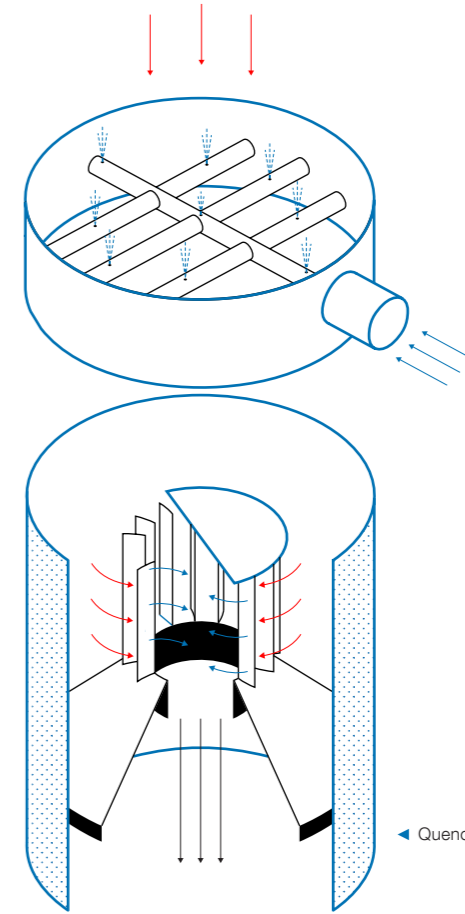

◀ Quench pipe and mixing tray operating principle

### Process and features

In multiple bed reactors, the process may require a cooling-down phase between two catalyst beds. This could be achieved by the injection of fluid, which is then collected and mixed with process fluid before the cooler process fluid is redistributed over the next catalyst bed.

# Outlet collector and support grid

Retention, support, and elimination of catalyst migration

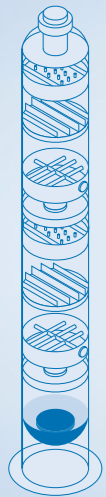

▲ Outlet collector

# Design according to your application

Meeting specific process requirements

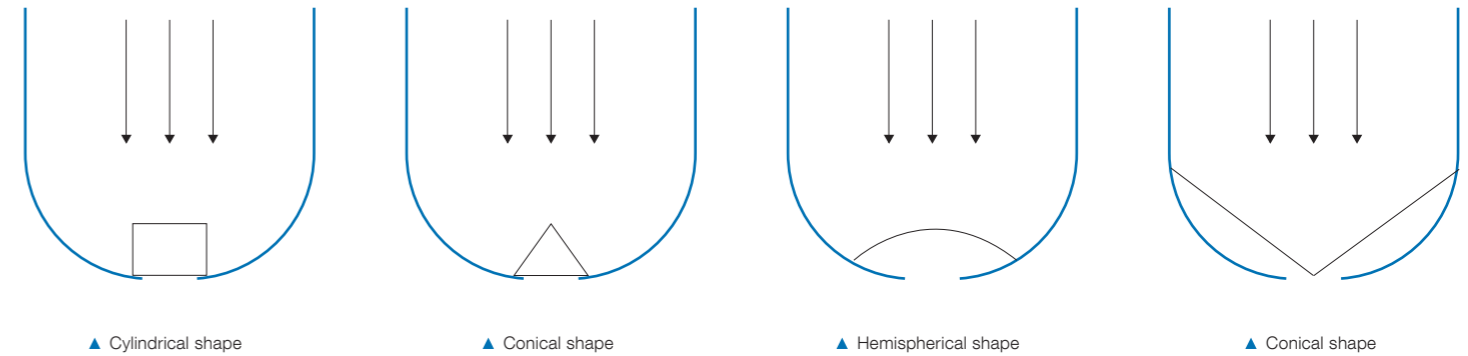

▲ Cylindrical shape

▲ Conical shape

▲ Hemispherical shape

▲ Conical shape

## Operating principles

The outlet collector collects the flow from the reactor to the outlet vessel nozzle. In a standard downflow pattern, the outlet collector is either hidden in an inert ball bed that fills the bottom part of the reactor or underneath a support grid, where it dis-

tributes or collects the flow. In the latter, it can also be designed as a safety retention device in case of catalyst leakage. Under reverse regeneration conditions or in normal upflow operation, the outlet collector is located below the top vessel nozzle,

where it operates in the opposite direction to a feed diffuser. In case of fluidization of the bed or possible entrainment of catalyst, it is designed to retain the catalyst. The same design features are implemented in order to ensure good sealing.

## Process and features

Several shapes are considered depending upon bottom vessel head, process conditions, and fluid dynamics. A cylindrical shape is the most common, but conical or hemispherical shapes are also possible. Catalyst unloading nozzles or a vessel opening for cleaning the outlet collector

are common requirements that impact the design of outlet collector. A better upstream flow can be achieved with a controlled open area or with deflectors. The purpose is to make the upstream flow as uniform as possible. The connection to the vessel head must seal off the shell. The

outlet collector sits either on the machined support or the centering ring. A locating sleeve can help to position the assembly and avoid any direct contact between the hot gas and the nozzle weld. The outlet collectors are usually installed in sectors passing through the vessel manway.

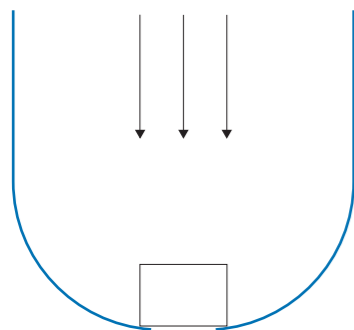

▲ Outlet collector submerged in bed

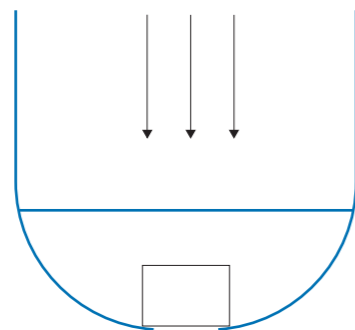

▲ Outlet collector below support grid

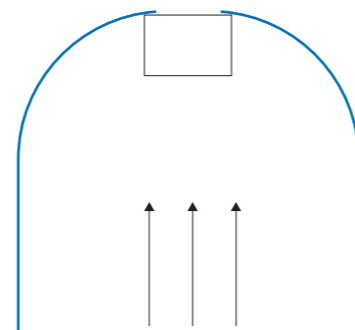

▲ Upflow conditions

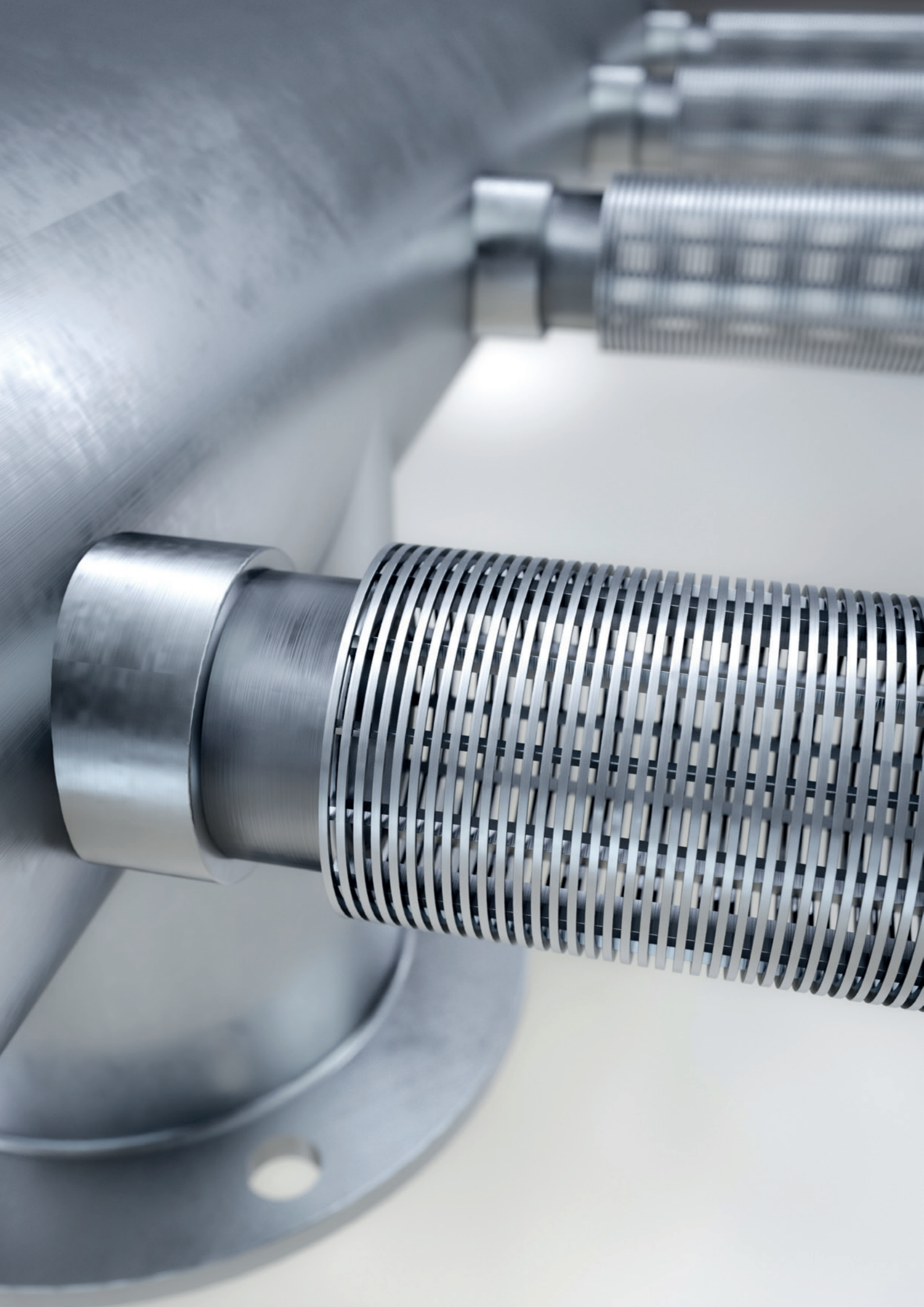

## Axial flow reactor

Header and hub lateral systems

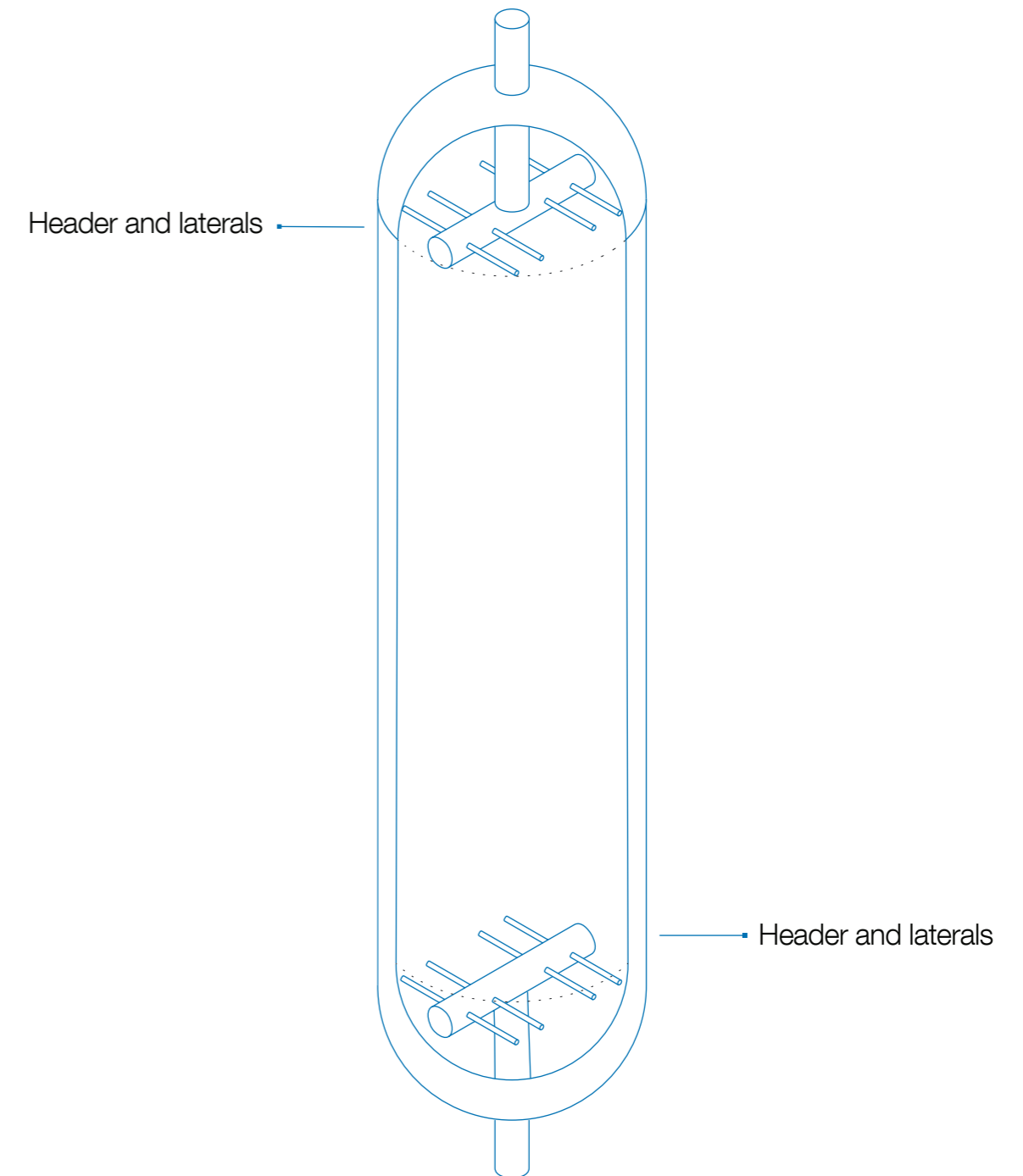

# Header and hub lateral systems

Uniform and excellent distribution

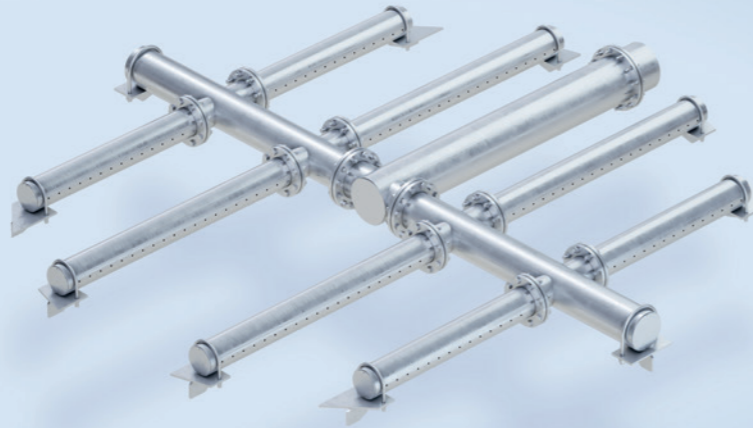

▲ Header and hub lateral system

# Design according to your application

Meeting specific process requirements

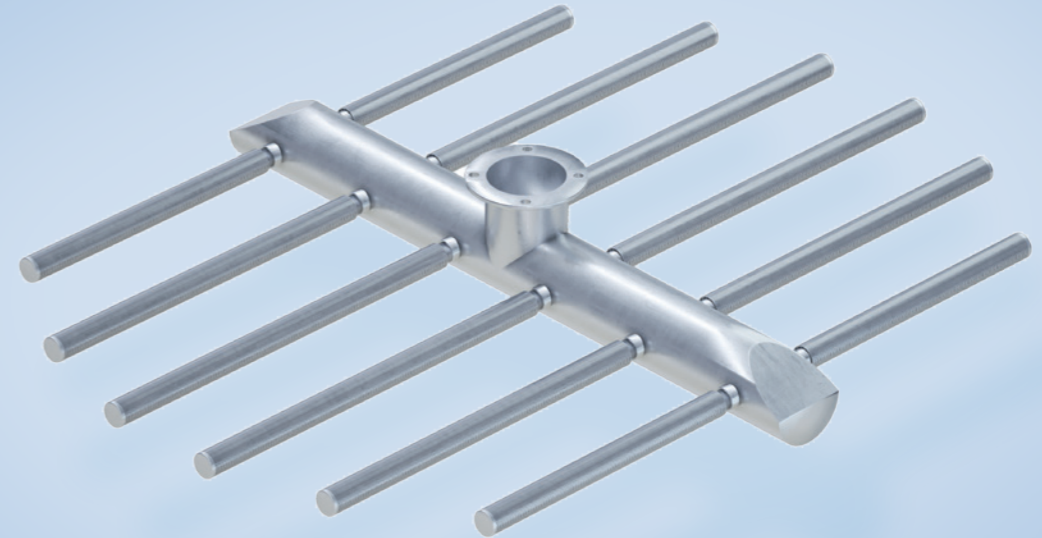

▲ Header and hub lateral system

## Operating principle

A collector/distributor uses a header pipe or a hub to which several screen tubes are attached in order to enable excellent collection or distribution of a gas or a liquid

within a medium without wall effects or channelling in order to maximize efficiency.

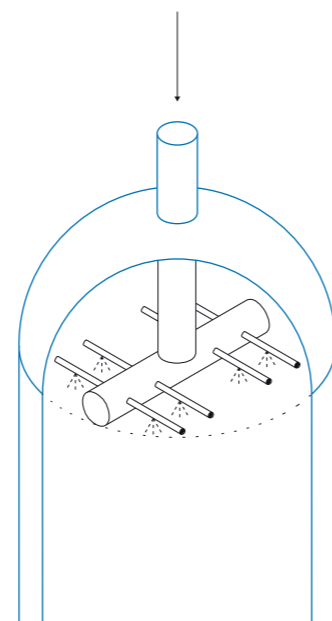

▲ Operating principle

## Process and features

Every project must be studied thoroughly – from the configuration of the vessel to the different nozzles – in order to select the best arrangement from “hub with spokes”, to parallel laterals and with or without

draining zone in order to adapt to the shape of the bottom of the vessel. Each lateral can be mounted on perforated pipes in order to optimize both mechanical resistance as well as collection/distribu-

tion efficiency with calibrated holes. This slip-on screen jacket can be dismantlable so that it can be removed for maintenance or cleaning purposes (process with highly erosive or corrosive environment).

# Radial flow reactor

Internals and solutions

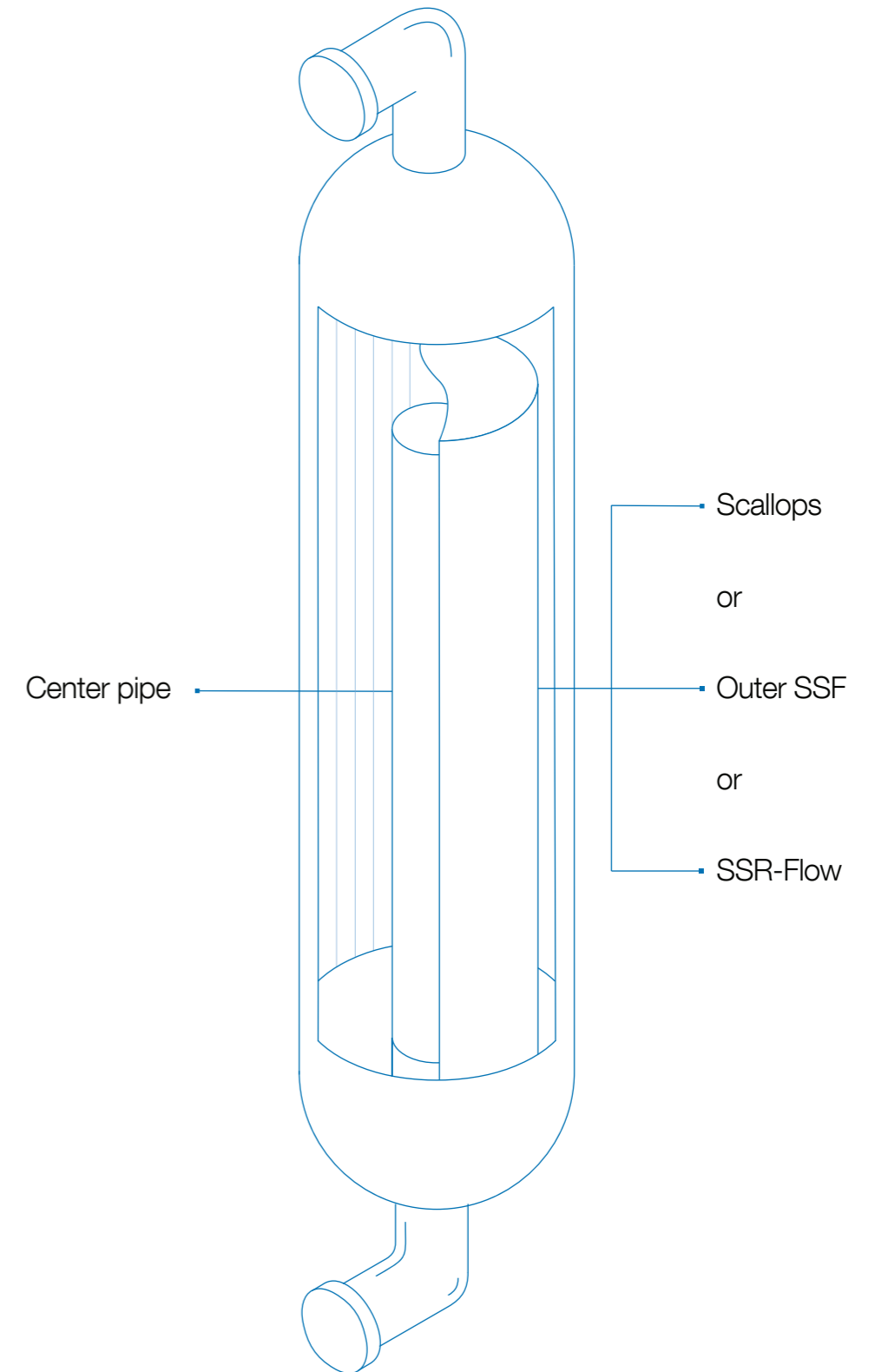
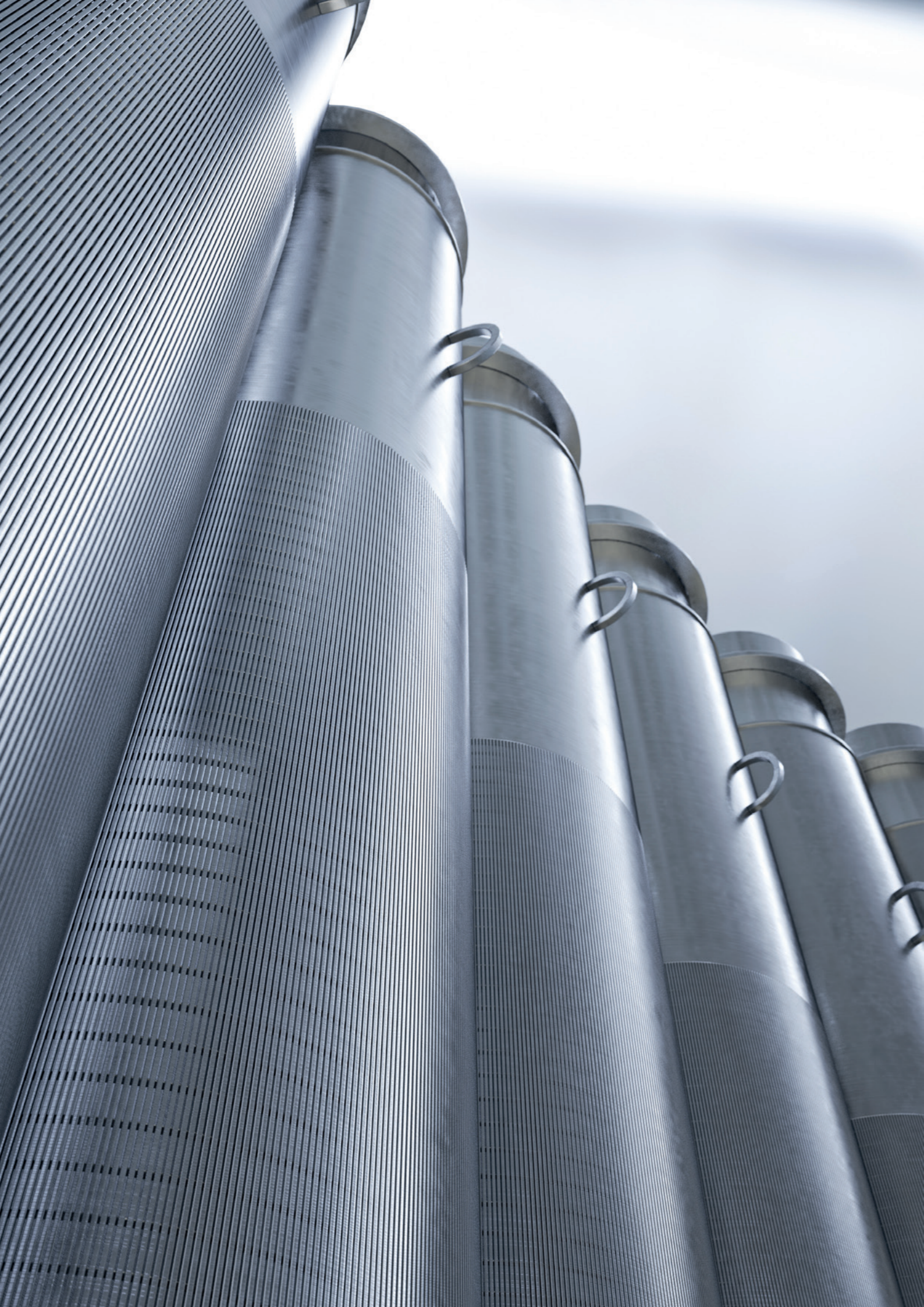

# Center pipe

High volume flow and efficient media retention



▲ Center pipe

## Operating principle

The center pipe/inner screen is the central screening components in radial flow systems. Its general shape is a cylinder, where the outer surface delimits the inner side of

the catalyst bed. It is usually installed inside vertical reactors and collects or distributes the flow.

# Design according to your application

Meeting specific process requirements

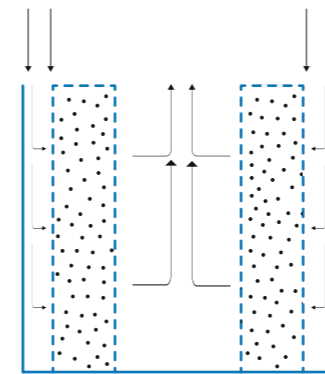

▲ Top inlet and top outlet flow

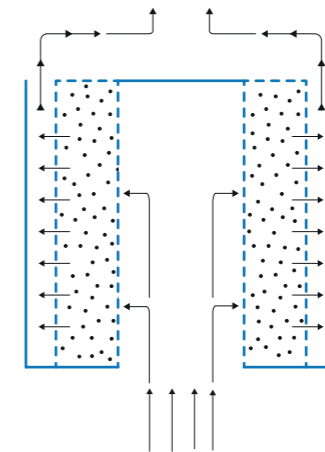

▲ Bottom inlet and top outlet flow

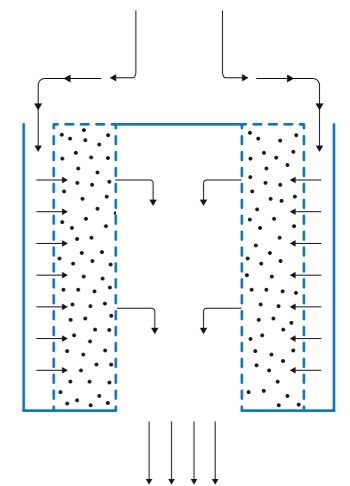

▲ Top inlet and bottom outlet flow

## Process and features

The connecting nozzle to the center pipe/inner screen is either the upper or the lower one. The flow direction can be inwards or outwards. Normally, the center pipe can be installed through the manhole in the top

of the vessel. It stands on a support that holds it in position. Generally, the center pipe is on the high temperature or high concentration side of the process flow as there is less stress on the vessel shell

when the high temperature and high concentration are in the middle. In addition, there is more room for thermal expansion along the vessel axis.

# Scallops

Easy-to-remove outer screen component parts

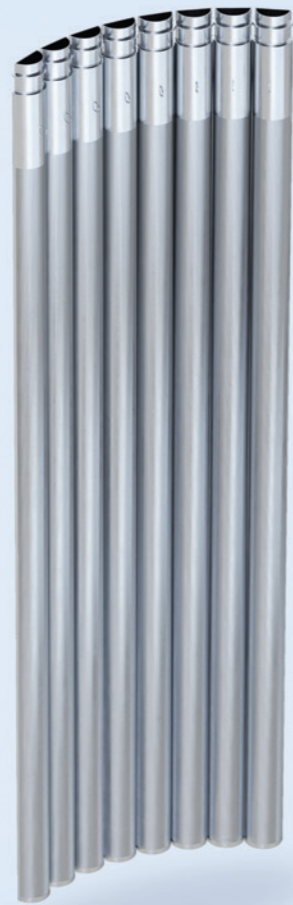
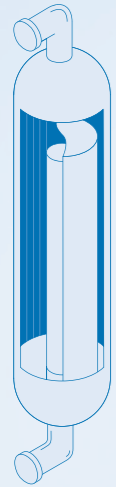

▲ Scallop

## Operating principle

The scallops assembly forms the outer screen component of a radial flow system. Its general shape extends parallel to the inner vessel wall using the wall as support.

The inner surface delimits the outer side of the catalyst bed. Its purpose is to distribute and collect the flow.

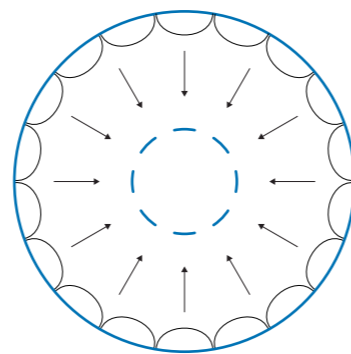

▲ Flow cross section

# Design according to your application

Meeting specific process requirements

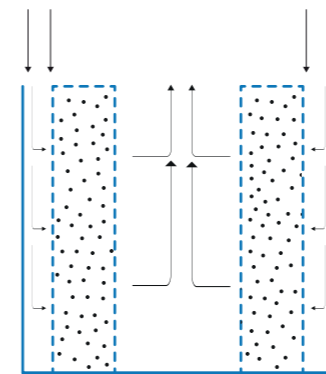

▲ Top inlet and top outlet flow

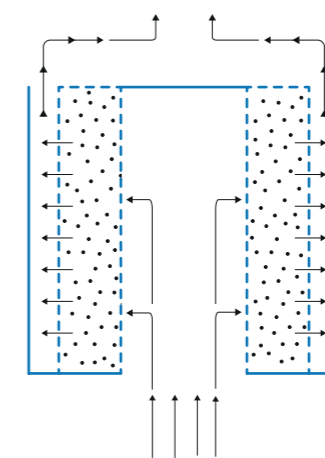

▲ Bottom inlet and top outlet flow

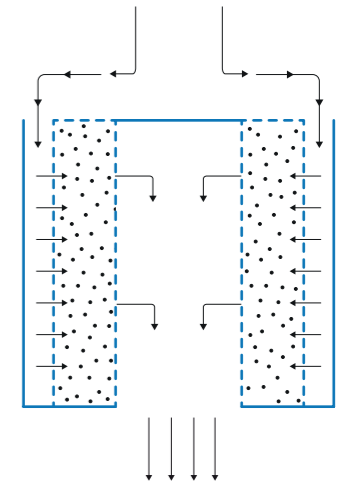

▲ Top inlet and bottom outlet flow

## Process and features

The cover deck closes the gap between the inner screen component and the scallops. The flow direction can be outwards or inwards. Scallops are usually introduced through the manhole in the top of the vessel. They rest on a support ring attached to the vessel wall.

Scallops are hollow conduits arranged along the inner surface of the vessel. They collect and distribute the gas flowing through them. The scallops are positioned adjacent to one another in a set. Each scallop cross section conducts a flow running parallel to the scallop's axis with, a

flow capacity limited to the cross section area. The total reactor capacity is the sum of the flow rate of each individual scallop. During high-temperature operations, some refractory or liner material may be applied to the vessel shell in order to prevent hot spots from forming.

# Outer basket

Robust and durable outer screen

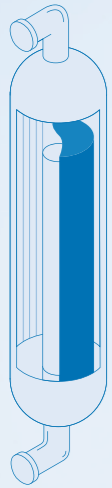

▲ Outer basket

## Operating principle

The outer baskets are the outer screen components of a radial flow system. Their general shape extends parallel to the inner vessel wall. The surface of the baskets

delimits the outer side of the catalyst bed and its purpose is to distribute or collect the flow.

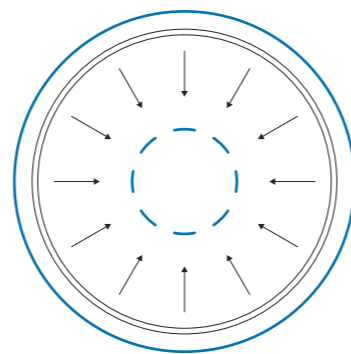

▲ Flow cross section

# Design according to your application

Meeting specific process requirements

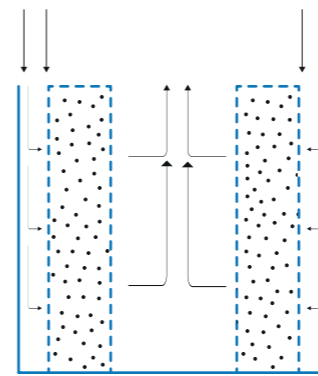

▲ Top inlet and top outlet flow

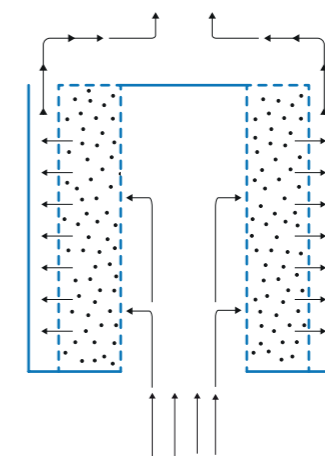

▲ Bottom inlet and top outlet flow

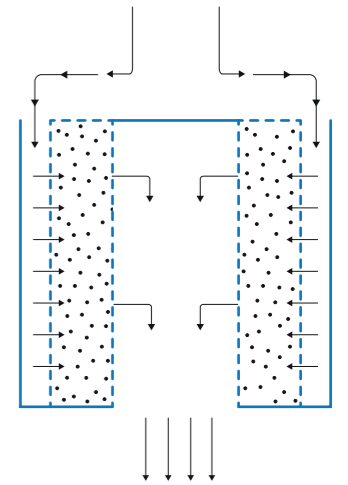

▲ Top inlet and bottom outlet flow

## Process and features

The cover deck closes the gap between the inner screen component and the outer basket. Here, the flow direction can be outwards or inwards. The outer basket is one single piece of equipment that has to be installed over the full vessel cross section. The equipment stands by itself on a

support ring attached to the vessel shell. As the outer basket is self-supporting, the distance between the inner vessel surface and the outer basket can be wider, thus allowing a higher flow capacity. The annular gap remains constant regardless of the direction of flow. As the outer basket is not

a part of the vessel shell, it must be able to withstand the full mechanical stress from the catalyst bed and thus is not compressed by the stress transferred from the vessel shell during temperature changes while in operation.



# SSR-Flow

Combining cylindrical shape and easy-to-remove component parts

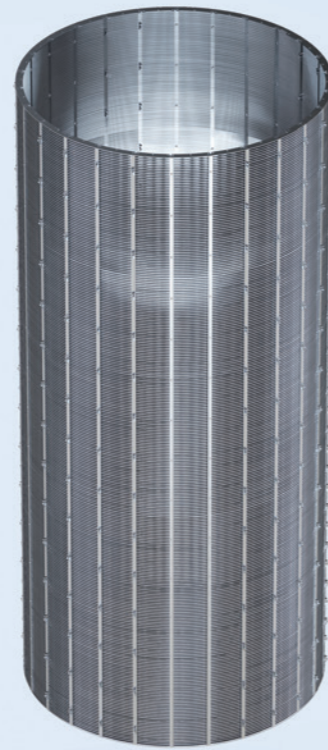
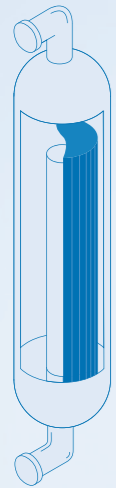

▲ SSR-Flow

## Design according to your application

Meeting specific process requirements

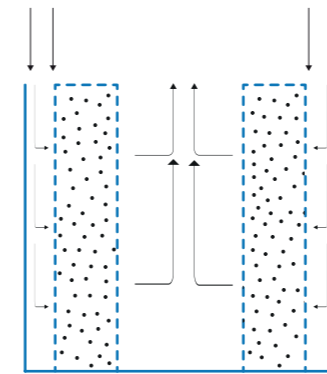

▲ Top inlet and top outlet flow

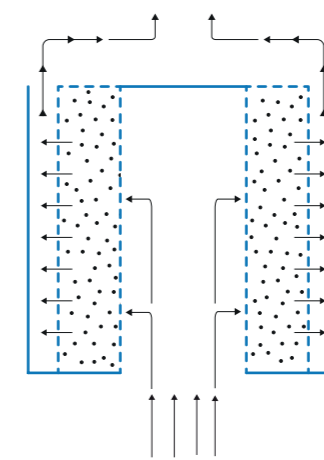

▲ Bottom inlet and top outlet flow

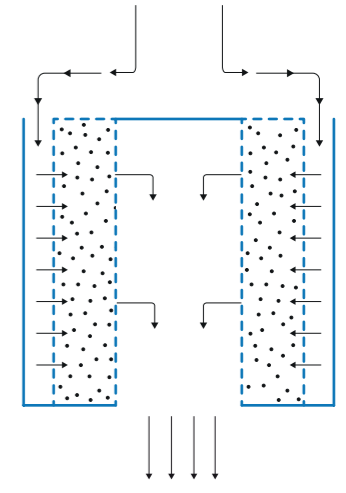

▲ Top inlet and bottom outlet flow

### Process and features

SSR-Flow is an external system for the retention of catalyst in radial flow reactors. It is a self-supporting vertical screen that is deployed into the peripheral ring containing the catalyst bed. No expander ring is necessary for installation of self-support-

ing SSR-Flow elements. This is an important advantage as expander rings disturb the circulation of catalyst in the radial bed. The male/female connection is secured by means of pins. Pin stoppers are installed from the interior surface of the SSR-Flow

at the time of assembly of the elements. The pin stoppers are hidden in the surface of the connection bar to ensure a smooth contact surface with the catalyst.

### Operating principle

The SSR-Flow assembly forms the outer screen component of a radial flow system. It enhances the outer basket technology by combining its cylindrical shape and flexibility of installation through the reactor

manhole. The SSR-Flow assembly is the ideal solution for replacing existing outer baskets instead of using standard scallops or bolted panels.

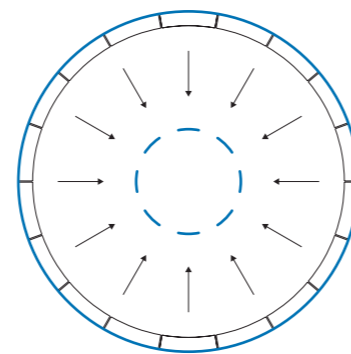

▲ Flow cross section

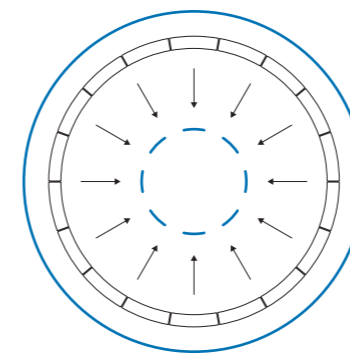

▲ Flow cross section with outer basket

# ANDRITZ Euroslot & ANDRITZ Fiedler

## Your partners for high-quality reactor internals

Over the past decade, ANDRITZ has developed comprehensive knowledge and expertise in cooperation with major licensing companies and EPC contractors in the hydrocarbon processing market. This is where ANDRITZ Euroslot is highly recognized for its ability to provide technology in accordance with strictest quality requirements.

AXENS, UOP, SHELL, Chevron Lummus Global, HALDOR TOPSOE, KBR, Badger, ENI Versalis, and other major companies have underlined their confidence in us by recommending ANDRITZ as one of their reliable suppliers of choice. Due to this close collaboration, ANDRITZ is recognized for its ability to design and produce high-quality catalytic reactor internals. In accordance with licensors and EPC specifications as well as international standards

and codes, our reactor internals have the following advantages:

- Uniform distribution
- Extreme pressure and temperature compliance
- Thermal stability of components
- Maximization of catalyst volume and duration of operating cycles
- Low fouling system reduction
- Potential pressure drop build-up

High-quality technology doesn't just happen. It is literally engineered into our manufacturing processes and services. That means using the latest laser technology, including laser welding techniques, as well as modern production control systems to ensure the highest visibility, while improving efficiency in the workshop. And we also invest heavily in the development of sophisticated software solutions to optimize

processes and to ensure strength, safety and integrity throughout our projects. These cutting-edge software solutions range from stress simulation to hydraulic and mechanical design. We constantly review and develop new approaches as well as new technologies to improve function, quality, and flexibility.

### Products for a wide range of applications

Our products and services include gas sweetening, gas drying, sulphur removal, hydrotreating, hydrocracking, hydrogenation, platforming, reforming, CCR, ammonia converters, styrene, PTA, MEROX, MTBE, ion exchangers, active carbon filters and many more.

### Benefits

- Certified and experienced engineers design and build your reactor internals in close cooperation with you
- Mechanical design that limits deflection during operation
- Our ANDRITZ engineers can advise you on how to optimize your processes by installing upgrades
- Strict manufacturing tolerances
- Trial assembly at the ANDRITZ Euroslot shop is a standard control procedure, which is assessed in a report where the measurements have to match the vessel's actual dimensions
- Documented welding procedures according to WPS with Procedure Qualification Record (PQR) enable the registration of the weld strength deformation as defined by mechanical requirements
- The metallurgical properties of each individual part and of the assembled components were assessed with a refractometer to ensure that stability remains consistent throughout
- Fast manufacturing due to ready-to-build drawings

## CONTACT

### **ANDRITZ Fiedler GmbH**

Weidener Strasse 9  
Regensburg, Germany  
Phone: +49 (941) 6401 0

### **ANDRITZ Euroslot SAS**

ZA Les Priédons CS 60050  
86140 Scorbé-Clairvaux, France  
Phone: +33 (549) 93 93 93

[www.andritz.com](http://www.andritz.com)